



MRE[®]
Pioneering Power Supplies



SPECIFICATIONS

MODEL No.: MRE5V29J
(5VDC @ 3A Wall Mounted Adapter)

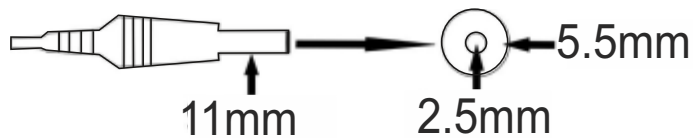

SPECIFICATIONS

MRE POWER SUPPLY PVT. LTD.

MODEL No.:MRE5V29J (5VDC / 3A, 15W Adapter)

1.0 SPECIFICATIONS

1.1. GENERAL

1.1.1. SCOPE : This specification defines the performance characteristics of Switching power Supply

1.2. INPUT CHARACTERISTICS

- 1.2.1. RATED INPUT VOLTAGE : 100VAC - 275VAC.
- 1.2.2. OPERATING INPUT RANGE : Minimum:100VAC, Nominal: 230VAC & Maximum: 275VAC.
- 1.2.3. INPUT FREQUENCY : 47Hz to 53Hz
- 1.2.4. INPUT CURRENT : < 800mArms @ 100VAC
- 1.2.5. EFFICIENCY : > 75% at all load conditions with complete AC input Operating Voltage (100VAC - 300VAC).
- 1.2.6. INRUSH CURRENT : < 30A Peak @ 230VAC Cold start at 25 Deg.
- 1.2.7. NO LOAD POWER : < 500mW at 230VAC input.

1.3. OUTPUT CHARACTERISTICS

- 1.3.1. OUTPUT VOLTAGE : 5VDC
- 1.3.2. OUTPUT CURRENT : Minimum: 0A (No Load), Maximum 3A.
- 1.3.3. LINE & LOAD REGULATION : 11.40 - 12.60VDC.
- 1.3.4. RIPPLE : < 120mV
- 1.3.5. NOISE : < 240mV
(measured with 0.1 μ F ceramic disc & 10 μ F EL Capacitor across the output terminals).
- 1.3.6. OUTPUT OVER CURRENT : 3.5A Max.
- 1.3.7. HOLD UP TIME : > 10 mSec. at 100VAC Input.
- 1.3.8. TURN-ON DELAY : < 3.0 Sec. at 230VAC input.
- 1.3.9. RISE TIME : < 10 mSec. at 230VAC input.
- 1.3.10. FALL TIME : < 10 mSec. at 230VAC input.
- 1.3.11. OUTPUT POWER LIMIT : 15.0W.
- 1.3.12. OUTPUT OVERSHOOT : < 10% of output voltage at all the conditions of input voltage.

1.4. PROTECTIONS

- 1.4.1. OUTPUT OVER LOAD / SHORT CIRCUIT PROTECTION : The power supply is protected against over load & short circuit. During over load & short ckt., the power supply will go to hiccup mode and resumes to normal operation on removal of fault condition. There by protecting the equipment connected to the power supply output from damages.
- 1.4.2. INPUT OVERVOLTAGE PROTECTION : The power supply is withstand upto 320VAC, without Interrupting the output voltage.

SPECIFICATIONS

MRE POWER SUPPLY PVT. LTD.

MODEL No.:MRE5V29J (5VDC / 3A, 15W Adapter)

1.4.3. OVERTEMPERATURE PROTECTION : The Power Supply is protected against the over load, during the over load the if PWM controller temperature exceeds **140 deg**, the unit will go into ON/OFF Mode and recover to normal operation when the temperature reduces.

1.5.0. ENVIRONMENT

1.5.1. TEMPERATURE : Operation: 0°C to + 40°C
Storage: -15°C to +70°C ambient.

1.5.2. HUMIDITY : Operation: 10% RH to 90% RH non-condensing.
Storage: 5% RH to 95% RH non-condensing.

1.5.3. VIBRATION TEST : The unit shall withstand vibration test (on power OFF condition) at frequency of 10 to 300Hz and acceleration 1g for 45min on each axis X,Y and Z.

1.5.4. BUMP TEST : The unit shall with stand 1000 Bumps with acceleration 40g under packing condition

1.5.5. FREE FALL TEST : The unit shall with stand free fall from a height of 1mtr on the hardwood with the thickness of 20mm in accordance with IS9000 (Part 7/Sec4) total no.of falls shall 8

1.5.6. DRY HEAT TEST : The unit shall with stand 55°C for 16Hr in power OFF condition.

1.5.7. COLD TEST : The unit shall with stand in unpacked condition with power off shall be subjected cold test of severity of 10°C for 2Hrs. carried out in accordance with IS9000(part-2,sec.4).The duration of recovery shall be 1 to 2 Hrs.To avoid condensation, equipment to be brought to ambient Temperature in controlled environment.

1.5.8. BURN-IN TEST : Burn in test as per IS14886:2000,sec.10.2.7 The duration of Test 40°C for 48Hrs. in power ON condition.

1.6.0. PRODUCT SAFETY AS PER IEC60950-1:

1.6.1. DI - ELECTRIC VOLTAGE WITHSTAND TEST (Hi-Pot) : 3.0KVrms, 50Hz for 60 Sec. (trip current set at 5mA). Between Shorted INPUT and Shorted OUTPUT Terminals. As per IEC 60950, 5.2.2 Test Procedure. And 5 Sec for Production.

1.6.2. INSULATION RESISTANCE : When tested with a 500VDC Megger I.R should be >50M Ohms Between Shorted INPUT and Shorted OUTPUT Terminals.

1.6.3 EARTH LEAKAGE CURRENT: The leakage current shall be < 0.25mA for Class II equipment when the power supply is operated at 265VAC input voltage.

SPECIFICATIONS

MRE POWER SUPPLY PVT. LTD.

MODEL No.:MRE5V29J (5VDC / 3A, 15W Adapter)

1.7.0 EMI / EMC STANDARDS

CE CISPER22	Conducted Emissions CISPR 22 / EN55022 Class A.
RE CISPR22	Radiated Emission CISPR 22 / EN55022 Class A.
IEC 61000-3-2	Harmonic current emissions.
IEC 61000-3-3	Voltage Fluctuation & Flicker
IEC 61000-4-2	Electrostatic discharge immunity (ESD), 8KVAir & 4KV Contact discharge.
IEC 61000-4-3	Radiated immunity upto 1GHz - RS.
IEC 61000-4-4	Electrical fast transient / burst (EFT): 2KV
IEC 61000-4-5	Surge Immunity testAC power line: L-L: 4KV, L-E: 2KV.
IEC 61000-4-6	Conducted Radio frequency disturbances test - CS.
IEC 61000-4-8	Power Frequency Magnetic field test.
IEC 61000-4-11	Voltage dips.

1.8.0 RELIABILITY & QUALITY

- 1.8.1 COMPONENT DERATING FACTORS : All semiconductors junction temperature shall not exceed the manufacturer's maximum thermal rating.
- 1.8.2 BURN-IN : The power supply shall be performed up to 48 Hours burn in at 40°C at full load on output and nominal input voltage of 230VAC. No abnormal functioning shall occur.
- 1.8.3 MTBF : > 50,000 hours at full load and 25°C ambient conditions.

1.9.0 TERMINATIONS

- 1.9.1. AC INPUT : Through an 3-Pin Integrated Plug as per the standard IS1293.
- 1.9.2. DC OUTPUT : Through a 1.25mtr length with 2.5/5.5mm connector .

1.10. ENCLOSURE

- 1.10.1. MATERIAL : ABS FR Plastic (UL94V -0).
- 1.10.2. DIMENSIONS : L = 85.0 mm. W = 48.0 mm. H = 30.0 mm.
- 1.10.3. ENCLOSURE MATERIAL : Black.
- 1.10.4. WEIGHT : Aprox. 250 Grams under packed condition.
- 1.10.5 AC PIN MATERIAL : Brass with Nickel plated.

SPECIFICATIONS

MRE POWER SUPPLY PVT. LTD.

MODEL No.:MRE5V29J (5VDC / 3A, 15W Adapter)

1.11.0. MECHANICAL DIMENSIONS & CONNECTION DRAWING:

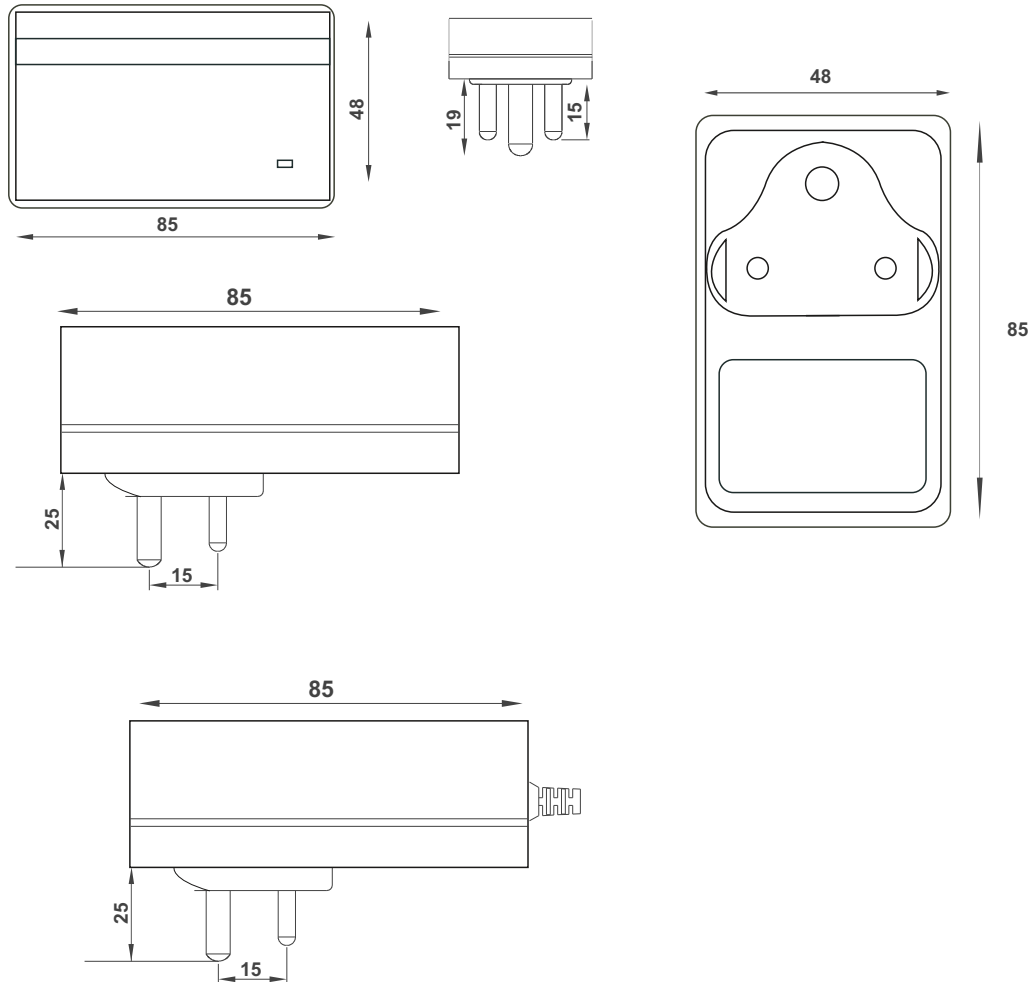

1.12.0. MARKING INFORMATION:

Lable on the
bottom of the side of the enclosure,

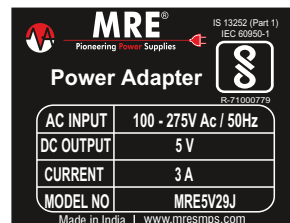

1.13.0. INDICATIONS:

RED led provided to indicate output ON.

1.14.0.APROVALS:

BIS approved

SPECIFICATIONS

MRE POWER SUPPLY PVT. LTD.

MODEL No.:MRE5V29J (5VDC / 3A, 15W Adapter)

1.15.0. PACKING INFORMATION:

BUFFER SHEET ARRANGEMENT METHOD	Put a Buffer Sheet over & under the Charger Packing Partition of each Layer
CHARGER PACKING / LAYER	20 No's
NUMBER OF LAYERS / CARTON	5 Layers
TOTAL PACKING QUANTITY	100No's
NET WEIGHT / EACH CHARGER	250.0 gms
MOTHER CARTON WEIGHT	22.0 Kgs

DIMENSIONS (MM)	L	W	H
CHARGER	85.0	48.0	30.0

CHARGER

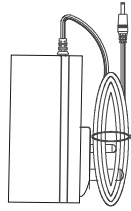

5PLY PARTI-

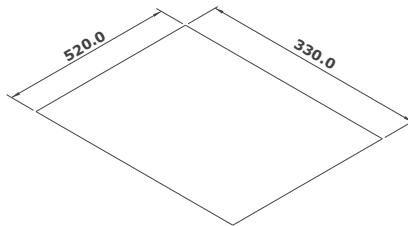

4PLY BUFFER

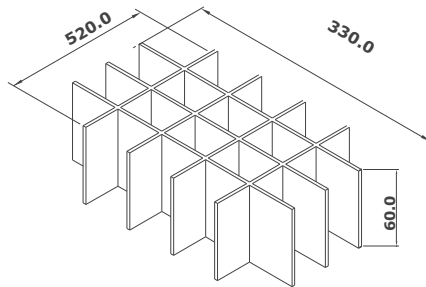

5PLY MOTHER

